

REELL RADIAL ELECTRIC CLUTCH

SHAFT NOM.	DIA. "A"	DIM. "B"	CROSS PIN SIZE	ONE MILLION CYCLE TORQUE RATING: [2.8 Nm] 25 Lb-in TOTAL LOAD.
1/4 6mm	.2505/.2530 [6.01/6.08]	.095/.103 [2.53/2.75]	3/32 [2.5]	6mm BORE SHOWN CROSS PIN SHAFT THREE DOG DRIVE HUB MOLDED COIL CONNECTOR

NOTES:

- CONNECTOR PINS ARE [0.64 x 0.64] .025 x .025 SQUARE. THE FOLLOWING MATING CONNECTORS CAN BE USED.
 TERMINAL: POLARIZED LATCHING CONNECTOR, INSULATION DISPLACEMENT CONTACTS
 AMP NO. 5-103956-1
 ALTERNATE TERMINAL:
 MOLEX NO. 14-60-0022
- RESISTANCE: 12 VOLTS 60 OHMS ± 10% AT [20°C] 68°F.
 24 VOLTS 227 OHMS ± 10% AT [20°C] 68°F.

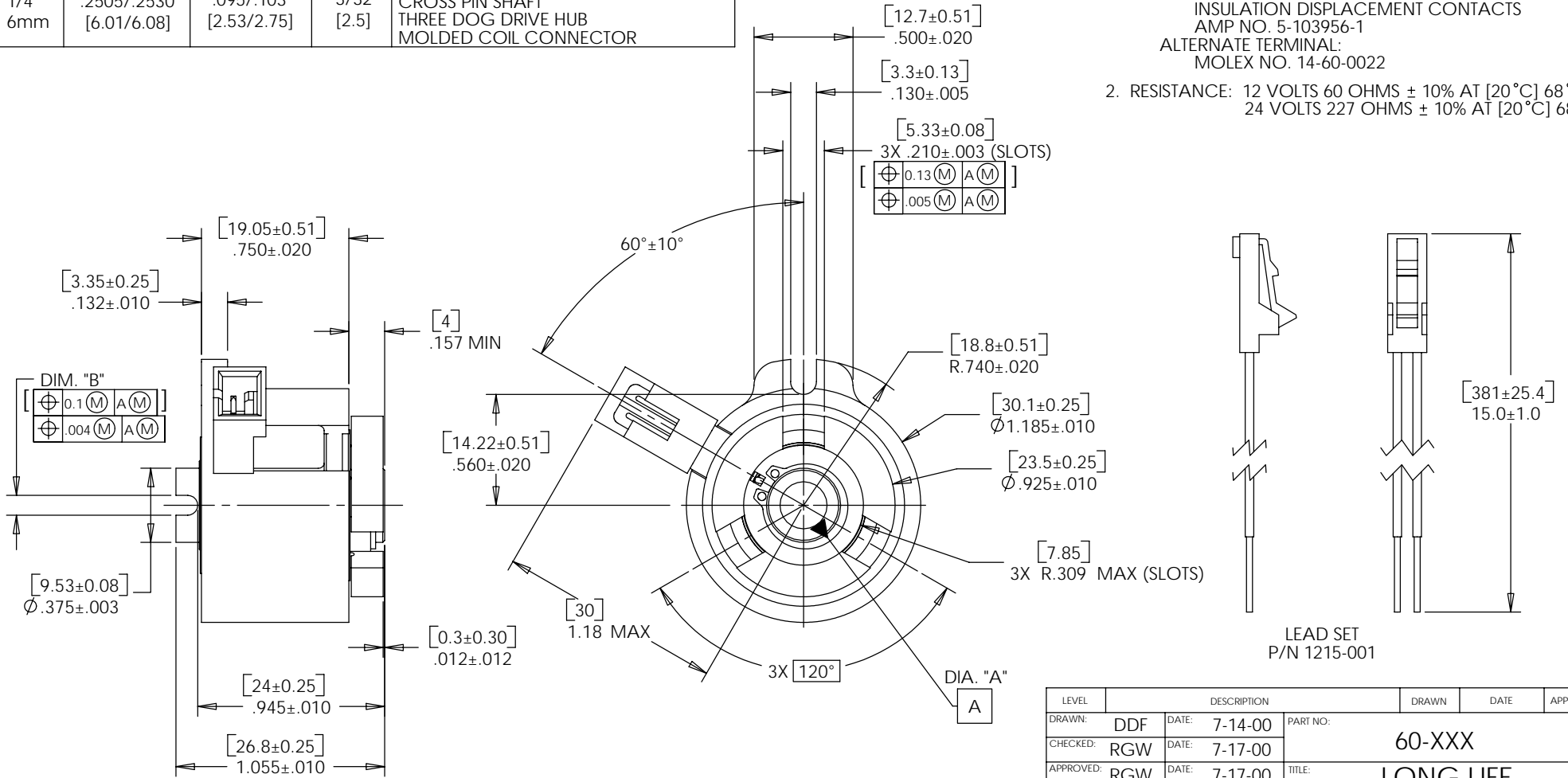

SPECIFICATIONS SUBJECT TO CHANGE

CONSISTENT WITH
ASME Y14.5M-1994
THIS PRINT IS THE
CONFIDENTIAL PROPERTY
OF REELL PRECISION MFG.
THIRD ANGLE PROJECTION

LEVEL	DESCRIPTION	DRAWN	DATE	APPROVED
DRAWN: DDF	DATE: 7-14-00	PART NO: 60-XXX		
CHECKED: RGW	DATE: 7-17-00	TITLE: LONG LIFE HIGH PERFORMANCE CLUTCH ASSEMBLY		
APPROVED: RGW	DATE: 7-17-00	DESCRIPTION: EC25LL		
REVISED: 2-7-06	DIMS: [mm]IN	REV: D		
REELL PRECISION MANUFACTURING 1259 WILLOW LAKE BOULEVARD SAINT PAUL, MINNESOTA 55110-5103, USA		SCALE: 2:1	DO NOT SCALE DRAWING	SHEET 1 OF 1