

REELL RADIAL ELECTRIC CLUTCH

SHAFT NOM.	DIA. "A"	DIM. "B"	CROSS PIN SIZE	ONE MILLION CYCLE TORQUE RATING: [8.5 Nm] 75 Lb-in TOTAL LOAD. ESTIMATED 100 MILLION INPUT REVOLUTIONS
3/8	.3755/.3780	.133±.003	1/8	3/8 IN BORE SHOWN CROSS PIN SHAFT THREE DOG DRIVE HUB
1/2	.5010/.5035	.133±.003	1/8	
5/8	.6260/.6295	.133±.003	1/8	
10mm	[10.01/10.08]	[3.2±0.08]	[3]	
12mm	[12.01/12.08]	[3.2±0.08]	[3]	
15mm	[15.01/15.11]	[3.2±0.08]	[3]	

NOTES:

- CONNECTOR PINS ARE [0.64 x 0.64] .025 x .025 SQUARE. THE FOLLOWING MATING CONNECTORS CAN BE USED.  
TERMINAL: POLARIZED LATCHING CONNECTOR, INSULATION DISPLACEMENT CONTACTS AMP NO. 5-103956-1  
ALTERNATE TERMINAL: MOLEX NO. 14-60-002
- RESISTANCE: 12 VOLTS 25 OHMS ± 10% AT [20°C] 68°F.  
24 VOLTS 100 OHMS ± 10% AT [20°C] 68°F.

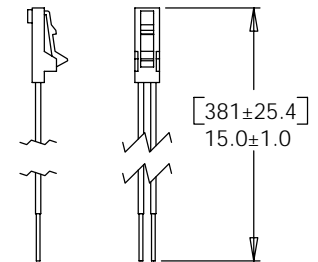
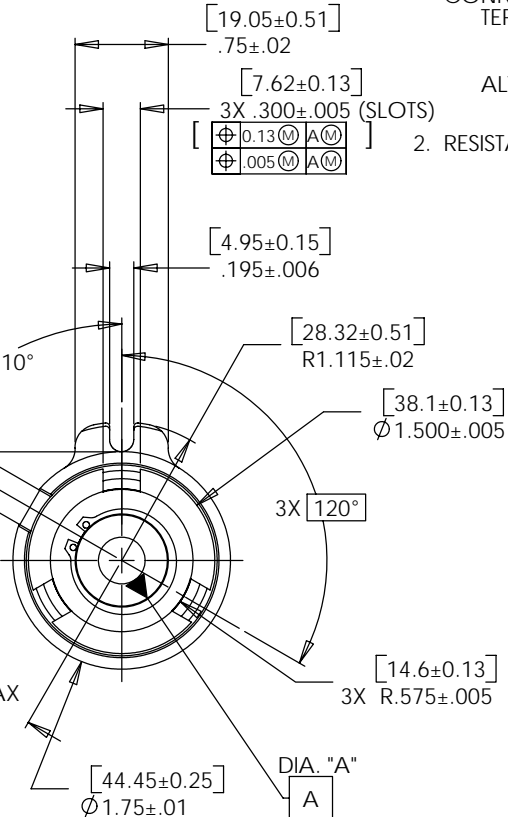
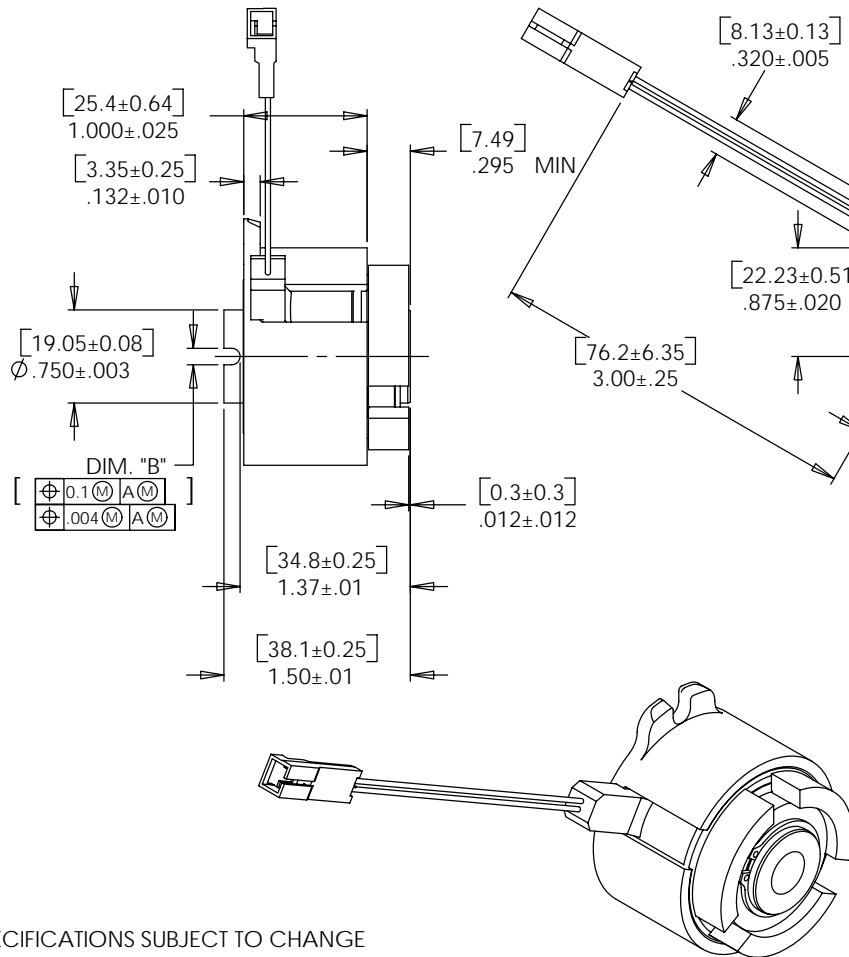

LEAD SET  
P/N 1215-001

SPECIFICATIONS SUBJECT TO CHANGE

LEVEL	DESCRIPTION	DRAWN	DATE	APPROVED
DRAWN: DDF	DATE: 5-14-02	PART NO: 38-XXX		
CHECKED: RGW	DATE: 5-15-02	TITLE: LONG LIFE HIGH PERFORMANCE CLUTCH ASSEMBLY		
APPROVED: RGW	DATE: 5-15-02	DESCRIPTION: EC75LL		
REVISED: 2-7-06	DIMS: [mm]IN	REV: F		
REELL PRECISION MANUFACTURING 1259 WILLOW LAKE BOULEVARD SAINT PAUL, MINNESOTA 55110-5103, USA		SCALE: 1:1	DO NOT SCALE DRAWING	SHEET 1 OF 1

CONSISTENT WITH  
ASME Y14.5M-1994  
THIS PRINT IS THE  
CONFIDENTIAL PROPERTY  
OF REELL PRECISION MFG.  
THIRD ANGLE PROJECTION

