

REELL SLIP CLUTCH

SHAFT NOM.	DIA. "A"	DIM. "B"	DESCRIPTION: SC-Nm-BORE SHOWN: 8mm BORE CROSS PIN AND "D" SHAFT THREE DOG DRIVE HUB	CURRENT TORQUES AVAILABLE SLIP TORQUE: [1.0 Nm] 8.8 Lb-in ±20% SLIP TORQUE: [1.5 Nm] 13.3 Lb-in ±20% SLIP TORQUE: [2.0 Nm] 17.7 Lb-in ±20% SLIP TORQUE: [2.5 Nm] 22.1 Lb-in ±20% SLIP TORQUE: [3.0 Nm] 26.6 Lb-in ±20% SLIP TORQUE: [3.5 Nm] 31.0 Lb-in ±20% SLIP TORQUE: [4.0 Nm] 35.4 Lb-in ±20%
5/16	.3130/.3230	.2615/.2655		
6mm	[6.01/6.2]	[5.01/5.1]		
8mm	[8.01/8.2]	[6.64/6.74]		

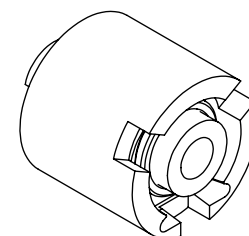
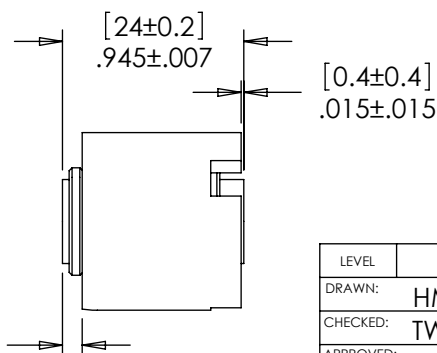
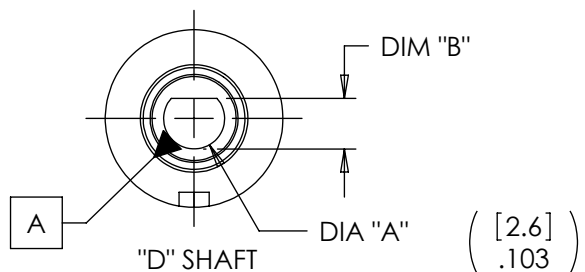
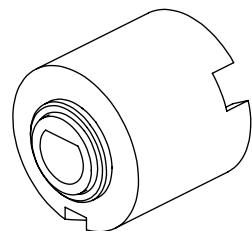
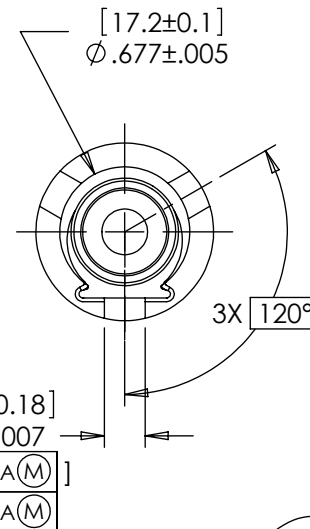
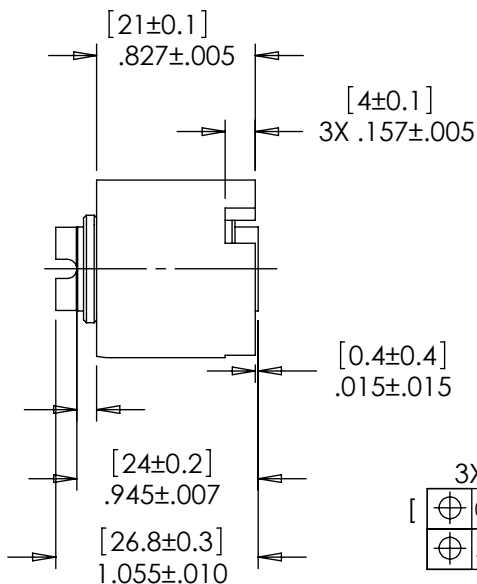
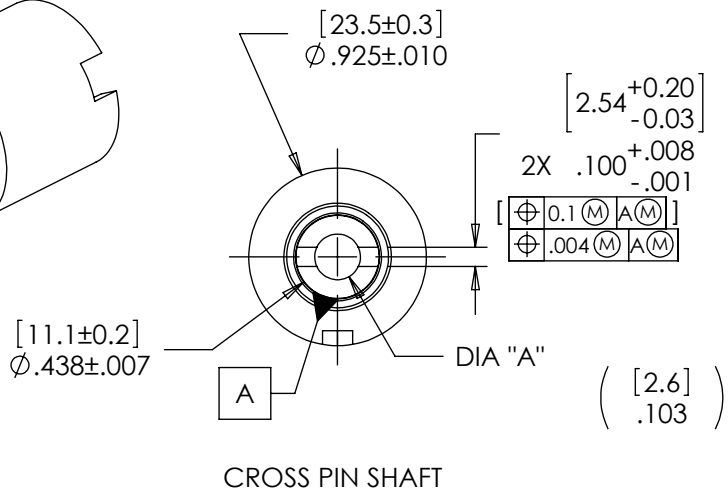
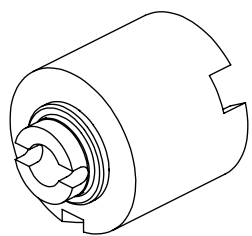

SPECIFICATIONS SUBJECT TO CHANGE

CONSISTENT WITH
ASME Y14.5M-1994
THIS PRINT IS THE
CONFIDENTIAL PROPERTY
OF REELL PRECISION MFG.

THIRD ANGLE PROJECTION

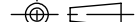

LEVEL	DESCRIPTION	DRAWN	DATE	APPROVED
DRAWN: HMA	DATE: 2-18-99	PART NO: 43-XXX		
CHECKED: TWJ	DATE: 4-17-01	TITLE: HIGH INERTIA SLIP DEVICE		
APPROVED: TWJ	DATE: 4-17-01	DESCRIPTION: SC		
REVISED: 5-6-10	DIMS: [mm]IN	REV: K		
REELL PRECISION MANUFACTURING 1259 WILLOW LAKE BOULEVARD SAINT PAUL, MINNESOTA 55110-5103, USA		SCALE: 1:1	DO NOT SCALE DRAWING	SHEET 1 OF 2

HIGH TORQUE	6mm	6mm"D"	8mm	8mm"D"
[INCHES] mm	PART NO.	PART NO.	PART NO.	PART NO.
[8.8] Lb-in 1.0 Nm	43-010	43-110	43-210	43-310
[13.3] Lb-in 1.5 Nm	43-015	43-115	43-215	43-315
[17.7] Lb-in 2.0 Nm	43-020	43-120	43-220	43-320
[22.1] Lb-in 2.5 Nm	43-025	43-125	43-225	43-325
[26.6] Lb-in 3.0 Nm	43-030	43-130	43-230	43-330
[31.0] Lb-in 3.5 Nm	43-035	43-135	43-235	43-335
[35.4] Lb-in 4.0 Nm	43-040	43-140	43-240	43-340

SPECIFICATIONS SUBJECT TO CHANGE

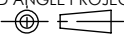
LEVEL	DESCRIPTION		DRAWN	DATE	APPROVED
DRAWN:	HMA	DATE: 2-18-99	PART NO: 43-XXX		
CHECKED:	TWJ	DATE: 4-17-01	TITLE: HIGH INERTIA SLIP DEVICE		
APPROVED:	TWJ	DATE: 4-17-01	DESCRIPTION: SC		
REVISED:	5-6-10	DIMS: [mm]IN	REV: K		
CONSISTENT WITH ASME Y14.5M-1994 THIS PRINT IS THE CONFIDENTIAL PROPERTY OF REELL PRECISION MFG.				REELL PRECISION MANUFACTURING 1259 WILLOW LAKE BOULEVARD SAINT PAUL, MINNESOTA 55110-5103, USA	
THIRD ANGLE PROJECTION 		SCALE: 1:1		DO NOT SCALE DRAWING	
				SHEET 2 OF 2	