

NOTES:

1.

	HIGH TORQUE	CCW LEFT	CW RIGHT	CW LEFT	CCW RIGHT
		PART NO.	PART NO.	PART NO.	PART NO.
[13.3] Lb-in 1.5 Nm		11-303	11-403	11-304	11-404
[22.1] Lb-in 2.5 Nm		11-305	11-405	11-306	11-406
[31] Lb-in 3.5 Nm		11-307	11-407	11-308	11-408
[39.8] Lb-in 4.5 Nm		11-309	11-409	11-310	11-410
[48.7] Lb-in 5.5 Nm		11-311	11-411	11-312	11-412

2. TORQUE LOW IS 65% OF HIGH TORQUE

TORQUE RANGE PER DIRECTION CONFIGURATION:
 STATIC HIGH TORQUE TOLERANCE $\pm 20\%$
 STATIC LOW TORQUE TOLERANCE $\pm 30\%$

DYNAMIC TORQUE IS NORMALLY WITHIN 10% OF STATIC TORQUE.

3. LIFE: 20,000 CYCLES WHEN DUTY CYCLES IS LESS THAN 10% AND ROTATIONAL SPEED IS LESS THAN 100 RPM. 30 SECONDS MAXIMUM CONTINUOUS ACTUATION.

4. SHAFT END TO BE ORIENTED $90^\circ \pm 5^\circ$ AS SHOWN WITH RESPECT TO DATUM A.

5. USER MUST DETERMINE FITNESS FOR USE IN APPLICATION.

6. DESIGNED TO ACCEPT M4 OR #8 SCREW OR EQUIVALENT.

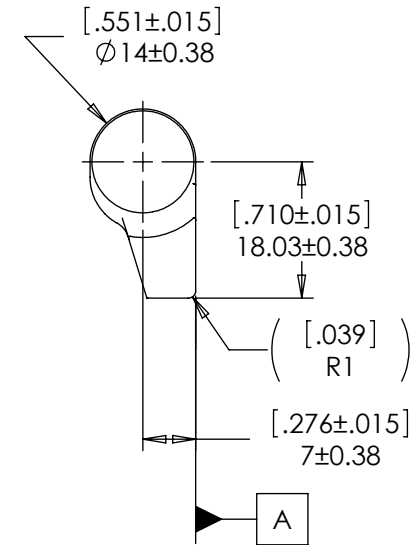
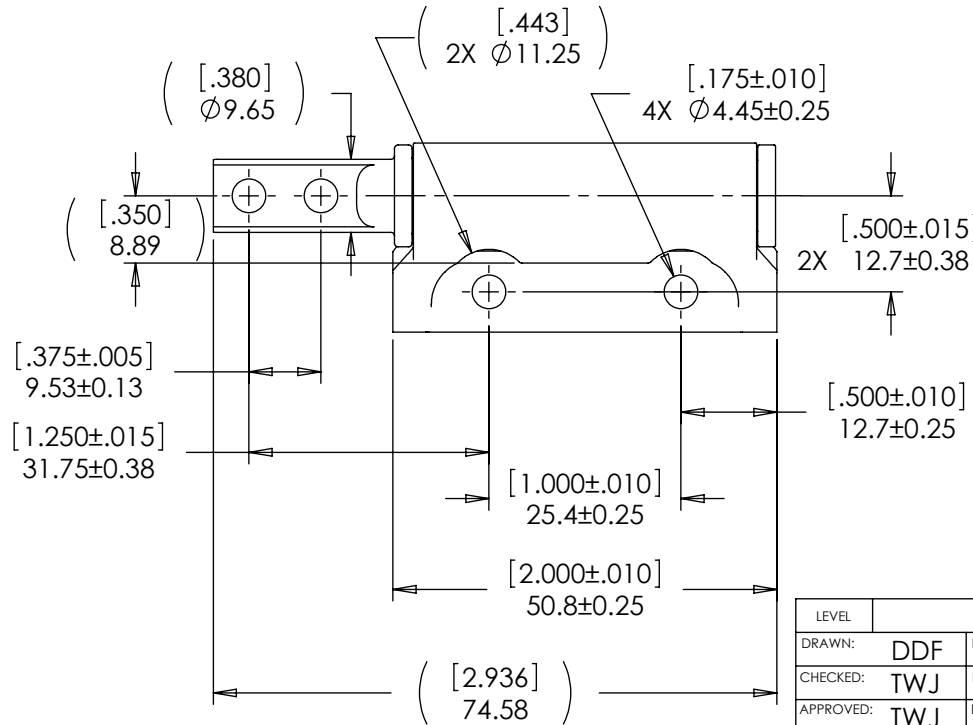
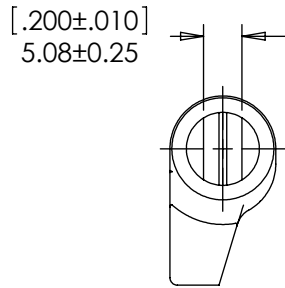
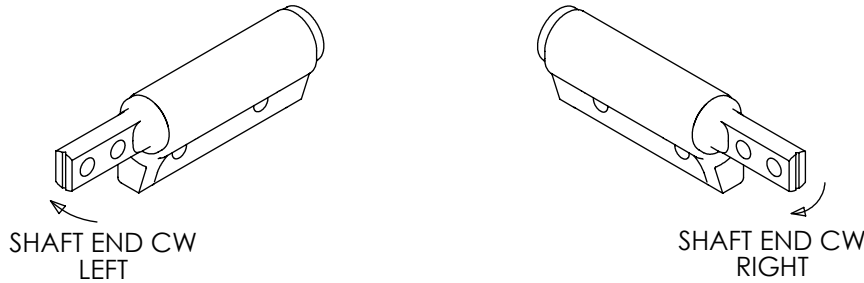

LEVEL	DESCRIPTION	DRAWN	DATE	APPROVED
DRAWN: DDF	DATE: 4-14-05	REFERENCE: APPL: 11-3XX,-4XX		
CHECKED: TWJ	DATE: 4-26-05	DESIGNER: TIM JENUM		
APPROVED: TWJ	DATE: 4-26-05	TYPE: SALES DRAWING		
REVISED: 6-1-11	DIMS: [IN]mm	TITLE: POSITIONING HINGE STRAIGHT LEFT AND RIGHT		
		PART NO: PHK SERIES	REV: H	
		REELL PRECISION MANUFACTURING 1259 WILLOW LAKE BOULEVARD SAINT PAUL, MINNESOTA 55110-5103, USA		
SCALE: 1:1		DO NOT SCALE DRAWING	SHEET 1 OF 1	

SPECIFICATION SUBJECT TO CHANGE

